

## A Review on Affordable Corrosion Monitoring Systems and System Development

Mahyad Komary, Seyedmilad Komarizadehasl, Nikola Tošić, and Jose Turmo

*Department of Civil and Environmental Engineering, Universitat Politècnica de Catalunya, Spain. E-mails:*

[mahyad.komary@upc.edu](mailto:mahyad.komary@upc.edu), [milad.komary@upc.edu](mailto:milad.komary@upc.edu), [nikola.tosic@upc.edu](mailto:nikola.tosic@upc.edu), [jose.turmo@upc.edu](mailto:jose.turmo@upc.edu)

**Abstracts:** Steel infrastructure degradation through atmospheric corrosion constitutes a major economic burden, exceeding \$2.5 trillion globally per year. Conventional monitoring approaches demand sophisticated instrumentation and considerable financial investment, constraining their application to critical high-value assets while leaving widespread conventional infrastructure unmonitored. This work synthesizes current developments in cost-effective corrosion sensing technologies and presents LEROY (Low-cost Electrical Resistance Ohm analyzer), an open-source IoT platform engineered for scalable atmospheric corrosion assessment.

Systematic analysis of 90 peer-reviewed studies identifies electrical resistance techniques as the predominant physical measurement approach, representing 25% of research focus within low-cost corrosion monitoring. Open-architecture microcontroller platforms, notably Arduino-family systems, have emerged as preferred solutions due to adaptability and network connectivity. Leveraging these insights, LEROY combines precision current sourcing, high-resolution signal conversion, and wireless telemetry in an integrated architecture.

Experimental characterization establishes milliohm-resolution measurement fidelity with 0.59% maximum deviation versus commercial instrumentation. Extended six-month accelerated exposure testing in 3.5% sodium chloride environment validated continuous metal loss tracking capability, achieving 3.31% agreement with conventional gravimetric assessment. Measured degradation rates of approximately 60  $\mu\text{m}/\text{year}$  align with ISO 9223 Category C4 corrosivity classification. Substantial cost advantages relative to commercial alternatives combined with IoT-enabled remote access demonstrate feasibility for large-scale sensor deployment across budget-limited infrastructure portfolios, enabling paradigm shift from episodic reactive maintenance toward continuous data-informed asset management.

*Keywords:* Low-cost sensing technologies; electrical resistance corrosion monitoring; open-source platforms; steel infrastructure; IoT systems.

### 1. Introduction

Atmospheric corrosion constitutes a primary deterioration mechanism threatening steel infrastructure integrity through thermodynamically spontaneous electrochemical processes. The World Corrosion Organization estimates annual global costs at \$2.4 trillion (3% of GDP), with developed nations experiencing corrosion-related damage approaching 3.5-4.5% of GNP [1]. For example, on 22 November 2013, atmospheric corrosion-induced wall thinning precipitated an oil pipeline rupture in Qingdao, China, resulting in an economic loss exceeding \$US123.9 million [2]. In addition to economic losses, corrosion might lead to structural collapses with consequent casualties. For instance, the August 2018 collapse of a 210-meter section of the Ponte Morandi viaduct in Genoa, Italy, where corrosion of concrete reinforcement constituted a

primary contributing factor, demonstrates the persistent threat posed by inadequately monitored atmospheric corrosion in civil structures [3]. These catastrophic events might have been prevented through corrosion monitoring programs. Effective corrosion monitoring systems comprise three essential components: sensing elements or probes deployed at susceptible locations to measure environmental parameters and material degradation, data acquisition (DAQ) systems for collecting and transmitting measurement data, and data processing infrastructure for analytical evaluation and archival storage [4]. Despite the demonstrable value of continuous corrosion monitoring for infrastructure asset management, implementation remains severely constrained by economic factors. The cost of commercial corrosion systems is a crucial determinant of their suitability for use

in given services. Table 1 presents a list of common corrosion monitoring devices with real-time updates available on the market for each technique, including their names, measurement ranges, and their retail prices (VAT excluded).

**Table 1** Commercial atmospheric corrosion monitoring systems and associated costs.

Method	Device	Corrosion Rate (mpy)	Price (\$US)	Ref.
ER	CST480AS	0.00394-39.34	3,300	[5]
EIS	CST1808	0.00394-0.3934	5,670	[6]
Galvanic	CST480MS	0.00394-39.34	3,300	[5]
LPR	AquaMate	0.01 - 200	2,925	[7]

In addition to these prices, the cost of data acquisition equipment (such as cables, a corrosion data logger, an inductance transmitter, and a corrosion management system) must be added. These needed auxiliary elements can increase the prices of the aforementioned sensors by up to an additional \$US7,000. The high cost of commercial corrosion monitoring systems, ranging from \$US10,000 to over \$US12,000 per measurement point when fully equipped for remote monitoring, effectively restricts structural health monitoring to high-value industrial assets such as petrochemical pipelines and offshore platforms. Meanwhile, infrastructure surveys indicate approximately 98% of bridge structures worldwide depend exclusively on periodic visual inspection rather than continuous sensor-based monitoring [8]. Consequently, substantial research need exists for affordable IoT-enabled corrosion monitoring solutions capable of extending continuous monitoring to conventional infrastructure operating under constrained budgets. Such systems must achieve measurement precision suitable for atmospheric corrosion assessment while maintaining costs substantially below commercial alternatives, enabling distributed sensor network deployment across bridge structures and industrial facilities.

## 2. LITERATURE SYNTHESIS: LOW-COST TECHNOLOGIES FOR CORROSION MONITORING

Recent advances in microelectronics, wireless communication protocols, and open-source software platforms have catalyzed significant research activity directed toward developing cost-effective alternatives to commercial corrosion monitoring instrumentation [9]. Komary et al. conducted systematic analysis of 90 peer-reviewed publications (1986-2021) addressing low-cost sensors and data acquisition systems for corrosion monitoring [10]. The systematic review methodology employed Boolean search operators combining terms related to low-cost technologies, corrosion monitoring methods, and sensor systems. Following initial retrieval and duplicate removal, 90 studies met inclusion criteria specifying direct implementation of affordable sensors or microcontrollers for corrosion assessment applications. Publications were classified according to measurement principle (electrochemical versus physical methods) and specific technique employed. For electrochemical approaches, the review examined electrochemical impedance spectroscopy (EIS), linear polarization resistance (LPR), galvanic methods, and electrochemical noise (EN). In the case of using electrochemical methods as the principal measurement technique, it was found that the majority of the authors (58%) focused their studies on the use of EIS, as it proved to be the most reliable and feasible method for corrosion monitoring applications in laboratory settings. However, the fundamental requirement for continuous electrolyte contact limits the applicability of all electrochemical methods for automated atmospheric corrosion monitoring of civil infrastructure. Physical methods encompassed electrical resistance (ER), optical fiber sensors, radio frequency identification, ultrasonic techniques, electromagnetic induction, and image recognition systems. Analysis of the 90 reviewed publications revealed that ER methods constitute the predominant physical measurement

approach within low-cost corrosion monitoring research, representing approximately 25% of total research focus. These two groups (ER and radio frequency methods) contain 25% and 23% of the publications from 1998 to 2021, respectively. This finding indicates substantial research community recognition of ER techniques as particularly well-suited for implementation through affordable sensor architectures. The physical basis of ER corrosion monitoring provides inherent advantages for low-cost deployment. The electrical resistance of a metallic conductor is governed by the fundamental relationship shown in Equation 1 [11].

$$R = \frac{\rho L}{A} \quad (1)$$

where  $R$  is electrical resistance,  $\rho$  is the material resistivity,  $L$  is the element length, and  $A$  is the cross-sectional area. As atmospheric corrosion progressively reduces metallic cross-sectional area, the electrical resistance of a sensing element increases proportionally, enabling direct quantification of metal loss through simple four-point resistance measurements without requiring continuous electrolyte contact or complex electrochemical instrumentation. Regarding data acquisition platforms, Arduino-family microcontrollers emerged as the preferred open-source solution for implementing low-cost corrosion monitoring systems [12], [13]. Numerous researchers have utilized as Arduino as an open-source DAQ system connected to low-cost sensors in their studies (illustrated in Table 2), exploring a range of physical characteristics crucial for SHM applications.

**Table 2.** Employment of Arduino and low-cost sensors in SHM applications

Micro. Cont.	Low-cost sensor	Application	Ref
Arduino Due	MPU9250	Acceleration, and Inclination	[14] [15]
Arduino Uno	DHT22	Temperature, and Humidity	[16]
Arduino Mega	HC-SR04 and VL53L0X	Distance measurements (Ultrasonic and Laser)	[17]

Despite progress documented in the reviewed literature, several gaps persist that limit the deployment of low-cost corrosion monitoring systems for civil infrastructure applications. First, while attention has been devoted to developing low-cost sensing elements, the development of economical DAQ systems represents a considerable portion of the overall costs in corrosion monitoring that has not been addressed. Second, the specific use of Arduino for developing a complete system to monitor corrosion rates through the ER method has not been explored. These identified gaps motivate the development of LEROY (Low-cost Electrical Resistance Ohm analYzer), an Arduino-based IoT platform engineered to address deficiencies in existing ER monitoring systems through integrated design addressing hardware precision, wireless connectivity, and comprehensive validation protocols (shown in Figure 1). The LEROY system objectives encompass: achieving milliohm-range measurement resolution through optimized analog front-end design and averaging algorithms; implementing autonomous wireless data streaming via integration of Arduino microcontroller and Raspberry Pi single-board computer architectures; validating measurement accuracy through direct comparison against commercial reference instrumentation (Hioki RM3548 resistance meter); and demonstrating long-term monitoring capability through extended accelerated corrosion exposure testing following standardized protocols (ASTM G44).

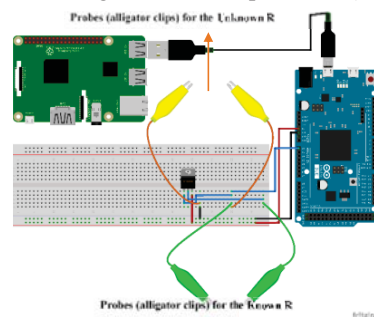

**Figure 1.** The assembled LEROY prototype showing component layout and connection.

### 3. MATERIALS AND METHODS

Experimental methodology comprised three phases: preliminary prototype evaluation, LEROY construction, and comprehensive validation. Hioki RM3548 resistance meter (resolution 0.01 mΩ, accuracy ±0.02%) served as benchmark reference throughout all phases.

#### 3.1. Data Acquisition System Evolution

Preliminary Arduino Uno R3 validation (10-bit ADC, 1,024 quantization levels) revealed fundamental limitations: accurate measurements only for resistance exceeding 50 Ω, with relative differences exceeding 100% for sub-ohm values critical for corrosion monitoring. Final LEROY architecture integrated Arduino Due microcontroller (32-bit ARM Cortex-M3, 84 MHz, dual 12-bit ADCs providing 4,096 quantization levels) with LM317T voltage regulator configured as constant current source (1.15 V reference, 0.01 Ω sensing resistor). Digital averaging enhanced resolution through oversampling at 20 Hz internal frequency, averaging ten consecutive samples per 0.5-second interval (shown in Equation 2).

$$V_{avg} = (1/N) \times \sum_{i=1}^N V_i \quad (2)$$

where  $V_{avg}$  represents the averaged voltage output,  $N$  denotes the number of samples averaged per output interval ( $N = 10$  for the implemented system), and  $V_i$  represents individual voltage readings acquired at the 20 Hz sampling rate. This averaging process effectively reduces uncorrelated ADC quantization noise by a factor proportional to  $\sqrt{N}$ , theoretically enhancing resolution by approximately 0.5 bits per doubling of the averaging factor. Following averaging computation, the firmware pipeline output resistance values at a final data rate of 2 Hz (one averaged measurement every 0.5 seconds), providing adequate temporal resolution for tracking atmospheric corrosion kinetics while maintaining manageable data storage requirements. Resistance measurements employed a 2-wire connection topology, which

inherently includes the resistance of lead wires and contact interfaces in the measurement. Unlike the 4-wire Kelvin method used by the commercial RM3548 reference meter, this approach introduces a systematic offset. To characterize this offset, the measurement terminals were short-circuited, and the apparent resistance was measured using the RM3548 in 4-wire mode. Prior to each validation test phase, a calibration procedure was conducted to quantify and compensate for residual resistance contributions from connecting cables, alligator clip contact resistances, and interface connections. These parasitic resistances were measured independently and subtracted from subsequent specimen measurements to ensure reported resistance values represented only the sensing element resistance. In the final iteration of the LEROY architecture, a Raspberry Pi 3 Model B+ single-board computer was integrated to enable remote data monitoring, autonomous data logging, and wireless network connectivity. Serial communication between the Arduino Due and Raspberry Pi was established via USB connection, with the Arduino transmitting ASCII-formatted resistance values at the 2 Hz output rate. A custom Python script executing on the Raspberry Pi automated the serial data acquisition process, parsing incoming data streams and logging timestamped resistance measurements to structured text files stored on the Raspberry Pi's microSD card. The integrated Wi-Fi capability enabled remote monitoring and data retrieval via Virtual Network Computing (VNC) protocols, providing remote desktop access for real-time observation of incoming resistance data and data file retrieval from remote locations via internet connectivity.

#### 3.2. Specimen Preparation and Experimental Configuration

Two categories of metallic specimens were prepared to demonstrate LEROY's measurement capabilities across resistance ranges representative of atmospheric corrosion monitoring applications. The first specimen

category comprised strips fabricated from AISI 1010 low-carbon steel sheet stock. Individual specimens were fabricated by cold-cutting electroplated sheet to produce strips measuring 300 mm in total length with thickness maintained at 0.2 mm and widths of 4 mm and 6 mm. The source material was electroplated with a nominal 6  $\mu\text{m}$  tin coating layer to provide temporary corrosion protection during handling while ensuring uniform initial surface conditions. For electrical resistance measurements, the 2-wire connection topology was used to measure the resistance of the central 260 mm length of each strip specimen. The second specimen category employed AISI Type 304HN austenitic stainless steel rod stock with 8 mm diameter. Two rod specimens were prepared with identical diameter but differing lengths of 130 mm and 150 mm to provide distinct resistance values for validation testing. These specimens were employed without protective coatings, as the inherent corrosion resistance of austenitic stainless steel provides stable resistance values during non-corrosive laboratory validation testing. All non-corrosive validation measurements were performed within the climate-controlled environment of the LATEM (Laboratorio de Tecnología de Estructuras y Materiales Lluís Agulló) laboratory at Universitat Politècnica de Catalunya. Specimens were positioned within a programmable environmental chamber configured to maintain constant temperature of 19°C and relative humidity of 50% throughout measurement periods. These controlled conditions eliminated temperature-induced resistance variations and humidity effects that might otherwise obscure evaluation of LEROY's intrinsic measurement capabilities.

### 3.3.3.3. Accelerated Corrosion Test Protocol

Following validation under non-corrosive conditions, a six-month accelerated corrosion test was conducted to evaluate LEROY's capability for quantitative corrosion tracking under aggressive exposure conditions. The test followed immersion corrosion guidelines outlined in

ASTM G31-21. An AISI 1010 steel strip specimen (260 mm  $\times$  4 mm  $\times$  0.2 mm, initial mass 1.72 grams) was fully immersed in 3.5% NaCl solution prepared by dissolving 35 g of NaCl in 1 L of distilled water at approximately 25°C without aeration or agitation. Electrical resistance values were recorded monthly using LEROY throughout the six-month exposure period. Following completion of the exposure period, final gravimetric validation employed ASTM G1-20 cleaning protocols, comparing calculated mass based on electrical resistance-derived corrosion depth against measured post-test mass.

## 4. 4. RESULTS AND DISCUSSION

### 4.1. Static and Dynamic Measurement Validation

Static measurements conducted over precisely timed 2-minute intervals demonstrated exceptional accuracy against the Hioki RM3548 reference instrument (illustrated in Table 3). For AISI 304HN stainless steel rods, LEROY achieved resistance measurements with maximum relative difference of 0.59% for the 150 mm specimen (absolute difference 0.012 m $\Omega$  compared to reference value of 2.035 m $\Omega$ ) and 0.49% for the 130 mm specimen. For AISI 1010 carbon steel strips, maximum relative difference of 0.07% was observed for both the 260 mm  $\times$  4 mm specimen (absolute difference 0.030 m $\Omega$  compared to reference value of 45.615 m $\Omega$ ) and the 260 mm  $\times$  6 mm specimen (absolute difference 0.020 m $\Omega$  compared to reference value of 30.155 m $\Omega$ ). Resolution analysis, conducted by identifying the smallest non-zero difference between any two distinct values in the measurement dataset, revealed achieved resolution of 7E-03 m $\Omega$  for AISI 304HN rod specimens and 3E-02 m $\Omega$  for AISI 1010 strip samples. This resolution capability proves particularly significant for structural health monitoring of steel bridges under atmospheric conditions, where typical thickness loss of 25 to 50  $\mu\text{m}/\text{year}$  produces electrical resistance changes in the range of 0.2 to 0.4 m $\Omega$  during early measurement periods. Precision metrics assessed

through coefficient of variation (CV) analysis demonstrated values of 0.27% maximum for AISI 304HN rods and 0.07% maximum for AISI 1010 strips during static measurements. The observed lower coefficient of variation for AISI 1010 strips, despite their higher absolute standard deviation, indicates that LEROY exhibits enhanced precision at higher resistance measurement scales characteristic of steel strip electrical resistance probes.

**Table 3.** Results of the static tests for both AISI 304HN and AISI 1010 specimens

Dynamic measurements conducted over 2-hour continuous monitoring intervals assessed long-term stability through drift analysis. Maximum observed drift values were 0.023 mΩ for the AISI 304HN 150 mm rod and 0.021 mΩ for the AISI 1010 6 mm strip. These drift magnitudes remain negligible relative to expected atmospheric corrosion-induced resistance changes. Dynamic measurement precision, quantified through coefficient of variation analysis, yielded maximum values of 0.98% for AISI 304HN rods and 0.08% for AISI 1010 strips, confirming consistent measurement precision over extended monitoring intervals.

**4.2. Six-Month Accelerated Corrosion Monitoring**

Monthly electrical resistance measurements tracked progressive corrosion throughout the six-month 3.5% NaCl immersion exposure, presented in Figure 2. Resistance increased from initial value of 45.58 mΩ in December 2023 to final value of 53.6 mΩ in June 2024, corresponding to calculated corrosion depth progression from 0.00 μm to 29.93 μm final thickness loss. Monthly corrosion rate calculations yielded values ranging from 52.30 μm/year to 59.69 μm/year, with average corrosion rate of approximately 60 μm/year. This measured corrosion rate aligns with ISO 9223:2012 corrosivity Category C4 classification (50-80 μm/year), characterized by very high corrosivity typical of industrial or

coastal atmospheric environments with elevated humidity and salinity.

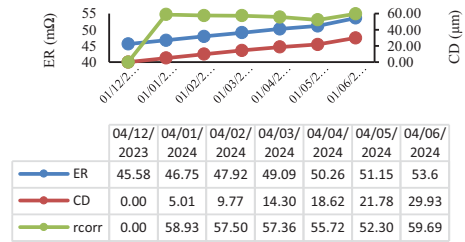

**Figure 2.** Corrosion progress over 6 months.

Spec.	Dimen. (mm)	LEROY (mΩ)	RM354 8 (mΩ)	Δ  (mΩ) <sup>a</sup>	Rel. Diff. (%) <sup>b</sup>
Rods	130 × Ø8	1.821	1.830	0.009	0.49
	150 × Ø8	2.023	2.035	0.012	0.59
Strips	260 × 4 × 0.2	45.585	45.615	0.030	0.07
	260 × 6 × 0.2	30.175	30.155	0.020	0.07

Gravimetric validation conducted following ASTM G1-20 cleaning protocols confirmed measurement accuracy. Final mass calculated based on electrical resistance-derived corrosion depth and initial specimen geometry, accounting for volume loss through progressive cross-sectional area reduction, yielded value of 1.46 grams. Measured final mass following chemical cleaning of corrosion products yielded value of 1.51 grams. The relative difference of 3.31% between calculated and measured final masses falls within acceptable ranges attributable to minor non-uniform corrosion effects, surface contaminants, measurement uncertainty, and specimen handling procedures. This close agreement between calculated and measured final masses validates LEROY's capability for quantitative long-term corrosion tracking under accelerated exposure conditions representative of aggressive atmospheric environments. The

<sup>a</sup> Absolute Difference

<sup>b</sup> Relative Difference

notable resistance increase observed in the final measurement period (from 51.15 mΩ in May 2024 to 53.6 mΩ in June 2024) exceeds the magnitude attributable solely to corrosion-induced thickness loss based on the established monthly progression trend. This anomalous increase reflects temperature effects on electrical resistance measurements, as the June measurement period coincided with elevated ambient temperatures. While a reference probe configuration was employed to provide baseline temperature compensation, potential thermal mismatch between corroding and reference probes contributes to measurement variations under non-isothermal conditions. This observation highlights the necessity for enhanced temperature compensation in long-term field deployments operating under diurnal and seasonal thermal variations. The fundamental temperature dependence of electrical resistance follows the relationship illustrated in Equation 3.

$$R_{20} = \frac{R_{raw}}{[1 + \alpha \times (T_{lag} - 20^{\circ}C)]} \quad (3)$$

where  $R_{20}$  represents temperature-normalized resistance at 20°C reference temperature,  $R_{raw}$  denotes measured resistance at ambient temperature,  $\alpha$  represents the temperature coefficient of resistance (approximately 0.0044/°C for AISI 1010 carbon steel), and  $T_{lag}$  accounts for thermal lag dynamics between the probe and surrounding environment. This temperature compensation algorithm, developed and validated in subsequent research phases, forms the technical foundation for the CORTEX system evolution that addresses the thermal drift limitations identified during LEROY validation testing.

## 5. Conclusion

LEROY demonstrates technical and economic viability as IoT-enabled atmospheric corrosion monitoring system for conventional steel bridge infrastructure. System cost (~€100) represents 100-fold reduction versus commercial alternatives (\$10,000-12,000 fully configured) through

Arduino Due, LM317 regulator, and Raspberry Pi integration. Validation established: (1) high accuracy with 0.59% maximum relative difference versus precision reference across milliohm ranges, (2) sub-10 μΩ resolution capability (7E-03 mΩ for stainless steel, 3E-02 mΩ for carbon steel) enabling minimal corrosion rate detection, (3) long-term stability with 0.023 mΩ maximum drift over 2-hour intervals. Six-month accelerated testing yielded 3.31% gravimetric agreement at ~60 μm/year corrosion rate (ISO Category C4). Order-of-magnitude cost reduction enables distributed sensor networks incorporating multiple measurement points across bridge structures, facilitating comprehensive spatial corrosion assessment and transition from reactive visual inspection toward proactive data-driven infrastructure management. Future development priorities: real-time temperature compensation algorithms (validated  $R@20$  relationship), wireless sensor network architectures for bridge-scale deployment, and machine learning for automated anomaly detection across distributed installations..

## Acknowledgement

This work was supported by project PID2024-161115OB-C21, funded by FEDER funds "A Way to Make Europe" and the Spanish Ministry of Science and Innovation MCIN/AEI/10.13039/501100011033..

## References

- [1] "WCO - World Corrosion Organization - 2024, April 24." Accessed: May 21, 2025. [Online]. Available: [https://corrosion.org/Events/Corrosion+Awariness+Day/2024\\_+April+24-p-2706.html](https://corrosion.org/Events/Corrosion+Awariness+Day/2024_+April+24-p-2706.html)
- [2] H. Ding *et al.*, "Evolution of polycyclic aromatic hydrocarbons in the surface sediment of southern Jiaozhou Bay in northern China after an accident of oil pipeline explosion," *Mar. Pollut. Bull.*, vol. 183, p. 114039, Oct. 2022, doi: 10.1016/J.MARPOLBUL.2022.114039.
- [3] N. D. Romano, *Applying FIDIC Contracts in Italy*, vol. ISBN: 9781. Informa Law from Routledge, 2022. doi: 10.4324/9781003201236-13.
- [4] M. Komary, S. Komarizadehasl, N. Tošić, and J. Turmo, "Development and validation

- of a novel IoT-enabled electrical resistance system for non-destructive monitoring of atmospheric corrosion in steel structures,” *Građevinski Mater. i Konstr.*, vol. 68, no. 3, pp. 107–122, 2025, doi: 10.5937/GRMK2500007K.
- [5] L. Wuhan Corrtest Instruments Corp., “CST480AS Atmospheric Corrosion Monitoring Device.” Accessed: Jan. 20, 2026. [Online]. Available: <https://www.corrp.com.cn/0875.html>
- [6] L. Wuhan Corrtest Instruments Corp., “CST1808 Coating Impedance Online Monitoring Instrument.” Accessed: Feb. 09, 2026. [Online]. Available: <https://www.corrp.com.cn/index.php?c=show&id=51>
- [7] J. H. Arellano-Pérez, O. J. Ramos Negrón, R. F. Escobar-Jiménez, J. F. Gómez-Aguilar, and J. Uruchurtu-Chavarín, “Development of a portable device for measuring the corrosion rates of metals based on electrochemical noise signals,” *Meas. J. Int. Meas. Confed.*, vol. 122, pp. 73–81, Jul. 2018, doi: 10.1016/J.MEASUREMENT.2018.03.008.
- [8] T. Panigati *et al.*, “Drone-based bridge inspections: Current practices and future directions,” *Autom. Constr.*, vol. 173, p. 106101, May 2025, doi: 10.1016/j.autcon.2025.106101.
- [9] M. Komary, S. Komarizadehasl, J. Turmo, F. Lozano, J. A. Lozano-Galant, and X. Ye, “A review on low-cost sensors compatible with open-source platforms used for life-cycle monitoring of civil structures,” in *Life-Cycle of Structures and Infrastructure Systems*, CRC Press, 2023, pp. 1685–1692. doi: 10.1201/9781003323020-207.
- [10] M. Komary, S. Komarizadehasl, N. Tošić, I. Segura, J. A. Lozano-Galant, and J. Turmo, “Low-Cost Technologies Used in Corrosion Monitoring,” *Sensors*, vol. 23, no. 3, p. 1309, Jan. 2023, doi: 10.3390/s23031309.
- [11] K. Popova, M. F. Montemor, and T. Prošek, “Application of Resistometric Sensors for Real-Time Corrosion Monitoring of Coated Materials,” *Corros. Mater. Degrad. 2024, Vol. 5, Pages 573-592*, vol. 5, no. 4, pp. 573–592, Nov. 2024, doi: 10.3390/cmd5040026.
- [12] S. Komarizadehasl, F. Lozano Galant, M. Komary, J. A. Lozano Galant, and J. Turmo Coderque, “Resolution improvement of low-cost MEMS accelerometer by aligning simulations sensors,” *IABSE Symp. Prague 2022 Rep. Challenges Exist. Oncoming Struct.*, pp. 1–6, 2022.
- [13] M. Komary, A. Alahmad, S. Komarizadehasl, J. Turmo, J. A. Lozano-Galant, and Y. Sun, “A novel low-cost inclinometer sensor based on fusion technology for structural health monitoring applications,” in *Life-Cycle of Structures and Infrastructure Systems*, CRC Press, 2023, pp. 1729–1736. doi: 10.1201/9781003323020-212.
- [14] S. Komarizadehasl, M. Komary, J. Turmo Coderque, V. Torralba Mendiola, F. Lozano Galant, and J. A. Lozano Galant, “Low-cost accurate acceleration acquisition sensor,” *Bridg. Safety, Maintenance, Manag. Life-Cycle, Resil. Sustain. Proc. Elev. Int. Conf. Bridg. Maintenance, Saf. Manag. (IABMAS 2022), Barcelona, Spain, July 11-15, 2022*, pp. 803–810, Sep. 2022, doi: 10.1201/9781003322641-96.
- [15] S. Komarizadehasl, F. Lozano, M. Komary, J. A. Lozano-Galant, and J. Turmo, “Development of an accurate low-cost device for structural vibration acquisition,” in *IABSE Symposium Prague, 2022: Challenges for Existing and Oncoming Structures - Report*, Prague: International Association for Bridge and Structural Engineering (IABSE), 2022, pp. 218–223. doi: 10.2749/prague.2022.0218.
- [16] M. Komary, P. Bajić, N. Tošić, A. De la Fuente, and J. Turmo, “Development of a Low-Cost IoT-based Sensor for Early-Stage Concrete Monitoring,” *Procedia Struct. Integr.*, vol. 64, pp. 1311–1317, Jan. 2024, doi: 10.1016/J.PROSTR.2024.09.202.
- [17] M. Komary, S. Komarizadehasl, N. Tošić, J. A. Lozano-Galant, and J. Turmo, “Advancing Smart Health Monitoring: A Review of Low-Cost Sensors for Structural Assessment,” *Procedia Struct. Integr.*, vol. 64, pp. 693–699, Jan. 2024, doi: 10.1016/J.PROSTR.2024.09.329.